



# SOLISTO AGM BATTERIES

SOL-12-110-AGM-T



## AGM BATTERIES DESIGNED FOR RENEWABLE ENERGY

Solisto AGM Batteries are specially designed for frequent cyclic charging and discharging. By utilizing strong grids, thick plates, and specially active materials they are designed for repeated deep-discharge applications.

Absorbent Glass Mat (AGM) technology makes the batteries safer to handle and utilizes special valves to help prolong the batteries' lifespan.



### Designed for Solar

Many off-grid solar systems are out in the middle of nowhere, sometimes hours away from the nearest town. When this is the case we know it's critical that your system has reliable batteries that require no maintenance, and are always ready. This is why Solisto batteries are designed to ensure that they can return from a deep discharge. These batteries are non spill-able, so there is no risk of acid leaks and unlike with flooded batteries, there is no need for water refilling.



### Certified and Tested

Solisto AGM batteries come with a robust set of certifications so you can have confidence in their reliability and usability. These certifications include ISO 9001 to ensure quality, ISO 14001 to ensure sustainability, and OHSAS 18001 to ensure worker safety. Solisto batteries are also UL Recognized (MH 65702) and CE Certified. We also ensure that our batteries are subjected to factory testing to ensure that every battery will meet or exceed their listed specifications.



### Long Battery Life

We know that batteries are often the most expensive and critical component in a power system, that's why Solisto AGM Batteries are designed to provide superior integrity and reliability. Absorbent Glass Mat (AGM) technology gives these batteries a much longer shelf life than flooded batteries, up to six months without a maintenance charge. Additionally, when kept in a floating charge state these batteries are designed to live for up to 12 years.



SHOP NOW



(866) 827-6527



## SPECIFICATIONS

Cells Per Unit	6
Voltage Per Unit	12
Capacity	110Ah@100hr rate to 1.75V Per Cell @77°F <sub>(25°C)</sub>
Terminal	Threaded Insert (M8-1.25)
Design Life	12 Years (floating charge)
Max. Discharge Current	1000A (5 sec)
Max. Charging Current	30A
Max. DOD	11.5V (20% SOC)

## BATTERY INFORMATION

Float Charging Voltage	13.6V~13.8V @77°F <sub>(25°C)</sub> Temperature Compensation: -3mV/°C/Cell
Cycle Use Voltage	14.6V~14.8V @77°F <sub>(25°C)</sub> Temperature Compensation: -4mV/°C/Cell
Normal Operating Temp Range	77°F <sub>(25°C)</sub> ± 9°F <sub>(5°C)</sub>
Operating Temperature	Discharge: -4°F <sub>(-20°C)</sub> ~ 140°F <sub>(60°C)</sub> Charge: 32°F <sub>(0°C)</sub> ~ 122°F <sub>(50°C)</sub> Storage: -4°F <sub>(-20°C)</sub> ~ 140°F <sub>(60°C)</sub>
Internal Resistance	Approx. 5.5 mΩ
Self Discharge	Solisto batteries can be stored for up to 6 months at 77°F <sub>(25°C)</sub> and then recharging is recommended. Monthly Self-discharge ratio is less than 3% at 77°F <sub>(25°C)</sub> Please charge batteries before using.

## REFERENCE CAPACITY

C3	76.4AH
C5	86.1AH
C10	95.2AH
C20	100.0AH
C100	110.0AH

## DIMENSIONS AND WEIGHT

Size (LxWxH) inches	12.9" x 6.8" x 8.7"
Size (LxWxH) mm	328 x 172 x 226
Weight	64Lb / 29 kg
Group Size	Group 31
Container Material	A.B.S. UL94-HB
Pallet Qty.	24
Pallet Dimension (LxWxH) inches	33" x 46" x 40"
Pallet Weight	1,590 lbs

## WARRANTY

[12 Month Limited Warranty](#)



### Certifications:

ISO 9001, ISO 14001, OHSAS 18001, UL Recognized, CE Certified

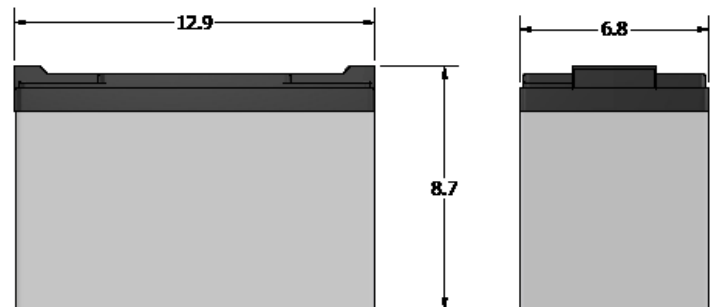

BATTERY DIMENSIONS



SHOP NOW



## CONSTANT CURRENT DISCHARGE CHARACTERISTICS : A(77°F) (25°C)

F.V / Time	10min	15min	30min	1hr	2hr	3hr	4hr	5hr	8hr	10hr	20hr
1.60V	230.7	184.6	108.9	60.74	36.17	28.17	22.10	18.80	12.06	10.00	5.183
1.65V	212.5	172.6	103.2	58.67	34.96	27.31	21.44	18.21	11.96	9.905	5.155
1.70V	196.9	162.3	97.81	56.79	34.03	26.15	20.78	17.72	11.77	9.714	5.090
1.75V	180.7	152.0	93.95	55.00	32.72	25.48	20.21	17.22	11.58	9.619	5.000
1.80V	164.4	139.2	90.49	52.56	31.60	25.00	19.74	17.00	11.39	9.524	4.952
1.85V	128.6	115.2	76.73	46.91	28.90	23.27	18.51	15.65	10.73	8.952	4.905

## CONSTANT POWER DISCHARGE CHARACTERISTICS : WPC(77°F) (25°C)

F.V / Time	10min	15min	30min	1hr	2hr	3hr	4hr	5hr	8hr	10hr	20hr
1.60V	392.8	322.0	197.9	114.0	68.39	53.50	42.59	35.58	23.50	19.61	10.35
1.65V	378.2	313.0	193.2	112.1	66.54	52.17	41.56	34.62	23.31	19.42	10.25
1.70V	353.0	296.3	183.9	108.8	64.88	50.17	40.23	33.76	23.03	19.05	10.16
1.75V	328.5	279.7	177.5	105.8	62.57	48.93	39.29	32.99	22.65	18.86	9.977
1.80V	302.6	258.5	171.8	101.4	61.15	48.65	38.53	32.54	22.28	18.67	9.885
1.85V	240.1	217.2	147.3	91.10	56.31	45.38	36.27	30.10	21.05	17.63	9.792

**NOTE:**

The above characteristics data are average values obtained within three charge/discharge cycles, not the minimum values. The battery must be fully charged before the capacity test. The C20 should reach 95% after the first cycle and 100% after the third cycle.



SHOP NOW



(866) 827-6527



**Discharge Characteristics Curve**

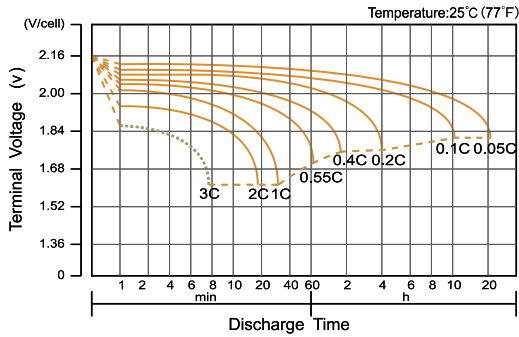

**Charge Characteristic Curve for Cycle Use(IU)**

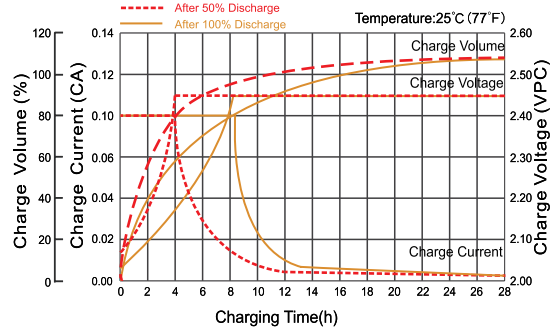

**Cycle Life in Relation to Depth of Discharge**

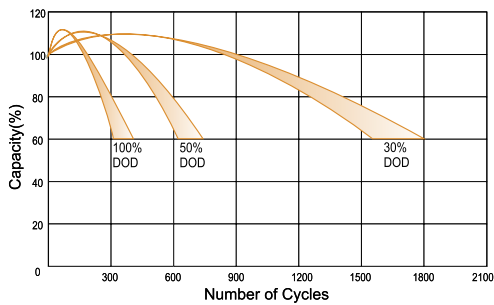

**Relationship Between Charging Voltage and Temperature**

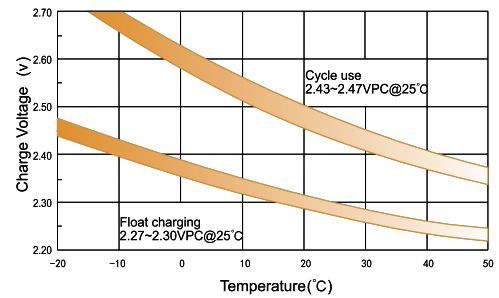

**Temperature Effects on Capacity**

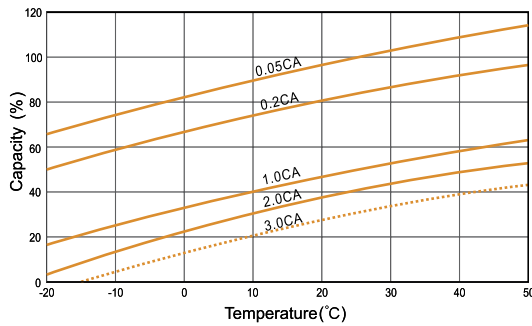

**Storage Characteristics**

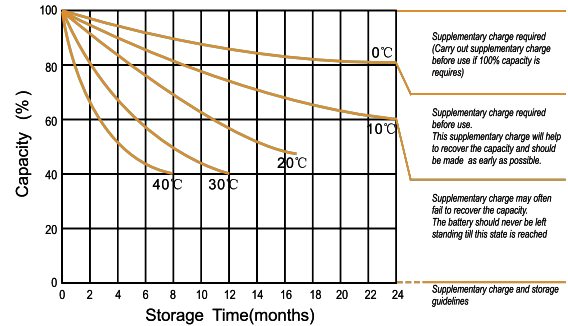

**Effect of Temperature on Long Term Life**

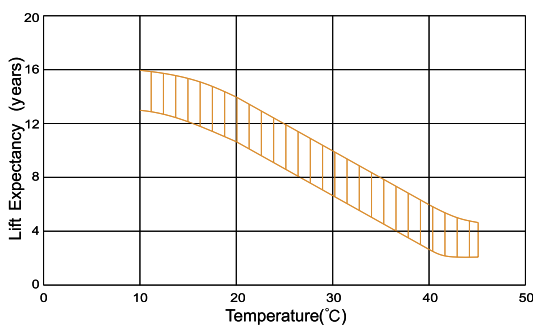

**Relationship of OCV And State of Charge(20°C)**

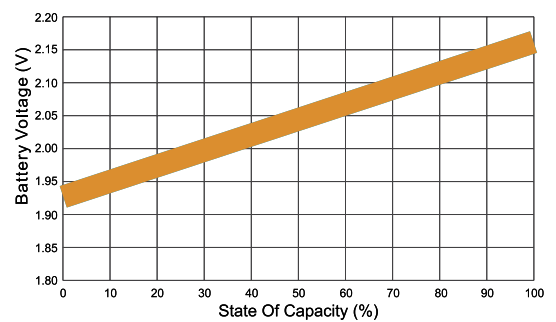

SHOP NOW



(866) 827-6527

