











Sunwize Power Ready Express

Quick Start

The purpose of this guide is to assist you in setting up your system quickly and efficiently.

Section Color Guide

- | | |
|-------------------------------|---|
| 1. Array Installation |  |
| 2. Enclosure Installation |  |
| 3. Control Panel Installation |  |
| 4. Solar (PV) Installation |  |
| 5. Battery Installation |  |
| 6. System Testing |  |
| 7. Connect your Equipment |  |
| 8. Calculate Tilt & Azimuth |  |

Share your installation photo:
email to marketing@sunwizepower.com



DAMAGE POSSIBLE!
Read and follow Red Electrical
Installation section of
this reference guide

Important! Prior to field installation

Determine and fill in the information below. Refer to <http://www.ngdc.noaa.gov/geomag-web/#declination> to determine required information using site Lat./Long. or zip code. See Pink Section (8) for detailed instructions.

Array tilt angle _____

Magnetic declination _____

See inside for list of required tools and additional materials.

For technical support call 541-666-5971

System Parts List

PV Modules
PV-Module mount
PV-Module output conductor kit
Enclosure
Enclosure mounting brackets (if required)
Batteries and battery cables
Control Panel
Installation Kit
(Optional) I/O Accessory Panel

You will need to supply these parts (not included):

Galvanized steel pole - 2"-8" sch 40 (if required)
Load wire - 18-6 AWG
Load conduit - 1/2" KO provided
Equipment grounding - 14-2 AWG lug provided, ground per local electrical code
Chest style only: Battery enclosure anchor bolts - 1/2" dia. (4 per enclosure)
Ground mounting only: Array mount anchor bolts - 1/2" dia. (4 per mount)
UV resistant cable ties

You will need these tools:

Wide, medium, and narrow flat head and Phillips screwdrivers
Socket driver set and open end wrenches (3/8" - 3/4")
5/32" Allen Wrench
3/16" Allen wrench
Magnetic compass
Tape measure
Grease pencil, chalk, scribe, or other marker
Digital multi-meter
Digital clamp on Amp meter (optional)



Photovoltaic (PV) modules generate electricity when exposed to light. Modules pose a shock hazard and risk of serious injury or death if instructions and safety precautions are not followed carefully. Cover the glass faces of the modules with opaque material while working on the system to stop the production of electricity. Avoid touching the terminals and isolate wire end until all connections are complete.

Batteries can explode or severely burn if the terminals are shorted to the opposite polarity. A single point system ground is required per NEC A.690. It is recommended to tie the battery negative (-) terminal to the equipment chassis at the time of installation. Always observe proper polarities when making electrical connections to the modules, batteries, and controller.

PV Array Installation: Pole Mount

Side of Pole Mount

1. Attach top of array structure to pole at desired maximum height using supplied band clamps or u-bolts.
2. Mount bottom tilt bracket on the PV array to pole. Turn array to face south and adjust to proper tilt angle for your location (refer to Appendix A in Manual).
3. Adjust placement of bottom band clamp or u-bolt referring to table below.

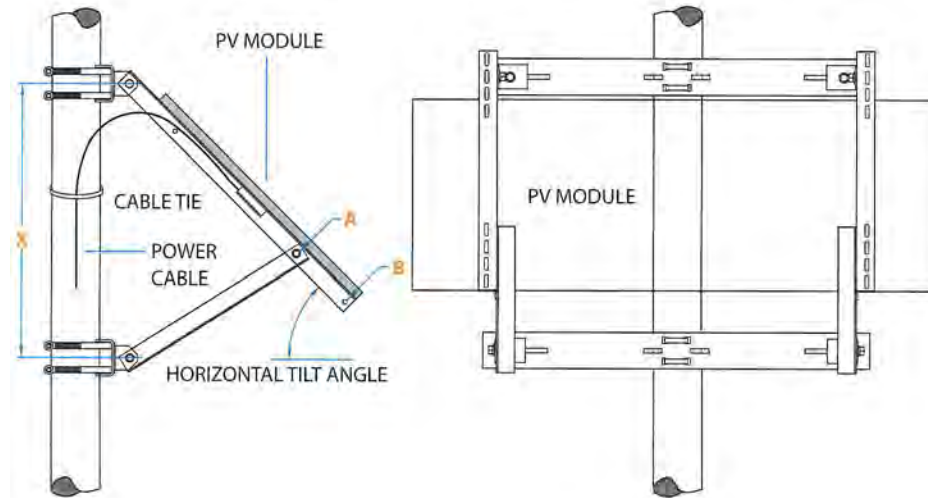

Top of Pole Mount

1. Attach array with the gimbal to the top of the pole.
2. Turn array to face South and fasten gimbal screws.
3. Set the tilt angle (refer to Appendix A in the manual) and tighten screws on L bracket.

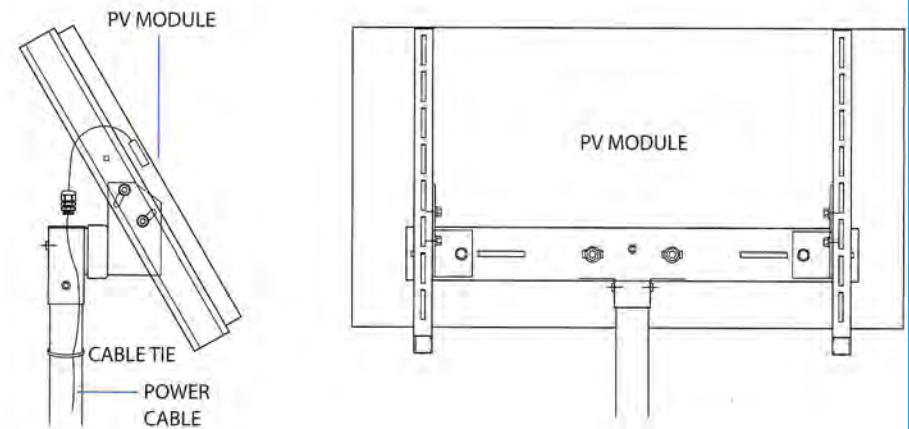

Horizontal Tilt	25°	30°	35°	40°	45°	50°	55°	60°
26.5" and 35" Rail								
Mounting Hole	A	A	A	A	B	B	B	B
X inches/mm	8.75/222.25	14.5/368.3	18.5/469.9	22/558.8	18/457.2	26.5/673.1	31/787.4	34/876.3
53" Rail								
Mounting Hole	A	A	A	B	B	B	B	B
X inches/mm	23.5/596.9	29.25/742.9	34.5/876.3	34.5/876.3	42/1066.8	48.25/1225.5	53.25/1352.5	57.5/1460.5

PV Array Installation: Ground Mount

1

Ground Mount

1. Turn array to face South.
2. Assemble per the manual provided with the mount.

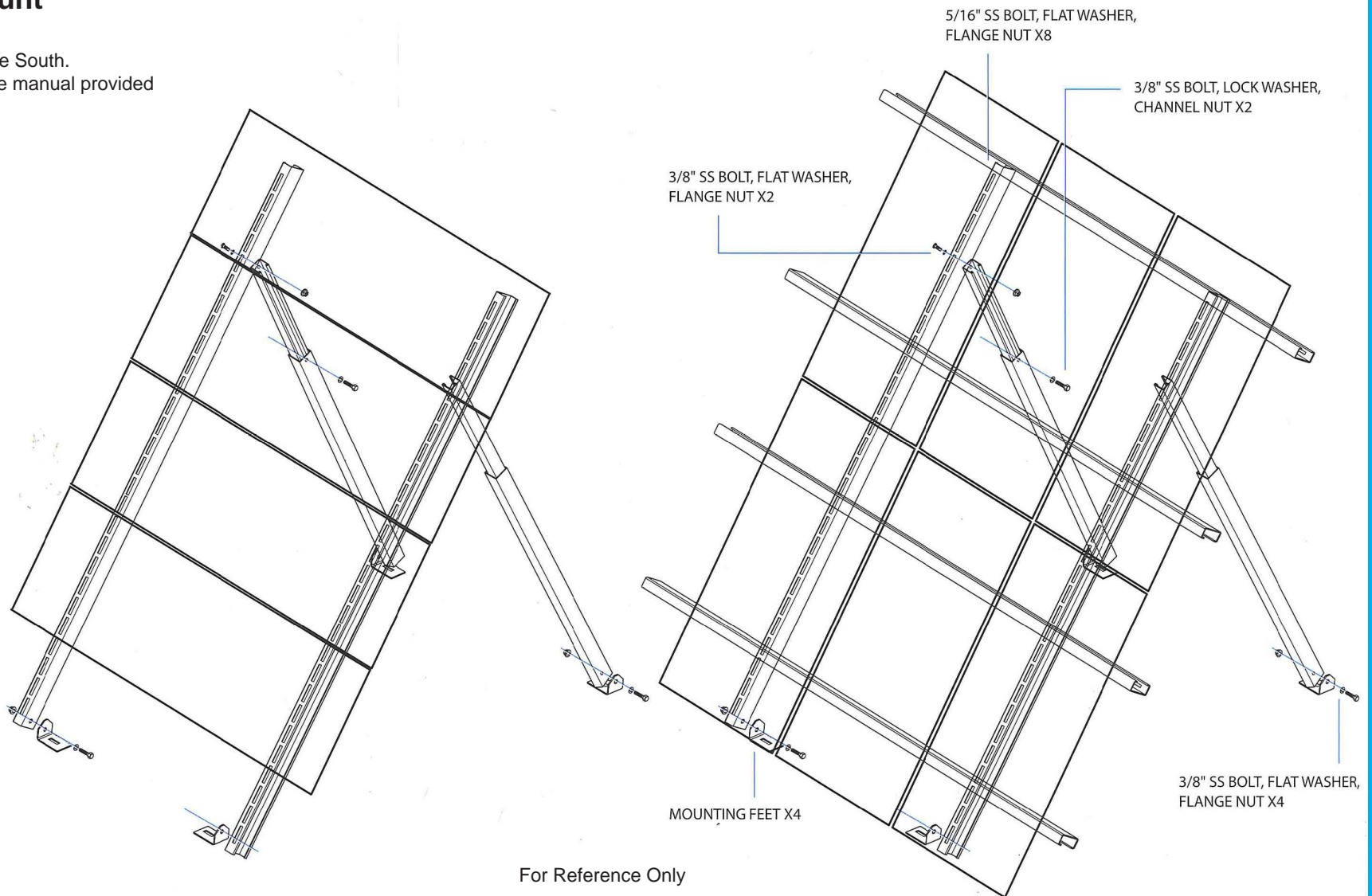

Enclosure Installation

2

Side of Pole Mount Enclosure

1. Mount upper mounting bracket at desired height of enclosure on the pole using U-bolts

Install the lower mounting bracket, Spacing should be measured from the upper bracket as follows:

Model	X inches/mm
WF2 or WF4 battery enclosure	23/584.2
F1 or F2 battery enclosure	12.7/327
F4 battery enclosure	24.1/612
F4 (tall) battery enclosure	39.1/993.14

2. Hang top of enclosure on top bracket - slip the tabs on either end of the mounting bracket under the tabs on the top of the back of the enclosure.
3. Attached lower bracket to enclosure

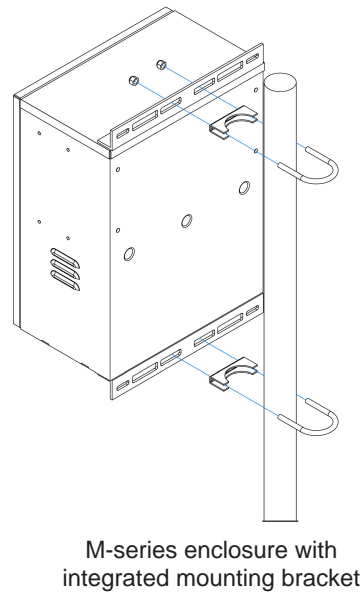
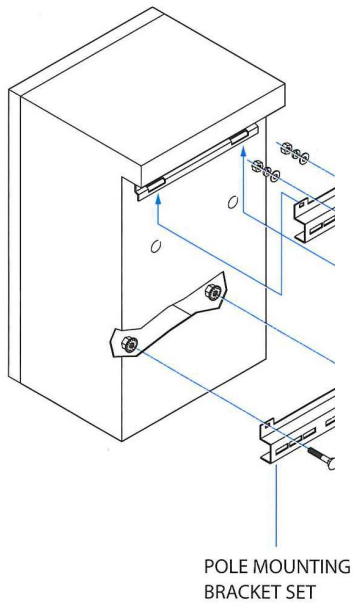

Ground Mounted Enclosure

1. Install the base mounting pads at the desired location using 1/2 inch concrete fastening hardware. Refer to the chart for dimensions and the diagram for enclosure mounting hole locations.
2. Check alignment and tighten bolts.

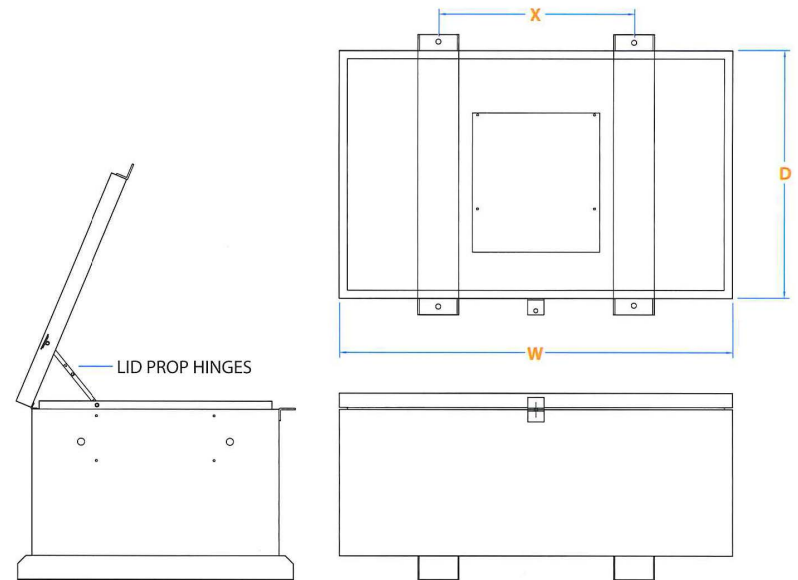

Enclosure Installation

2

Side of Pole Mount Enclosure

1. Mount upper mounting bracket at desired height of enclosure on the pole using U-bolts

Install the lower mounting bracket, Spacing should be measured from the upper bracket as follows:

Model	X inches/mm
WF2 or WF4 battery enclosure	23/584.2
F1 or F2 battery enclosure	12.7/327
F4 battery enclosure	24.1/612
F4 (tall) battery enclosure	39.1/993.14

2. Hang top of enclosure on top bracket - slip the tabs on either end of the mounting bracket under the tabs on the top of the back of the enclosure.
3. Attached lower bracket to enclosure using the round carriage bolts.

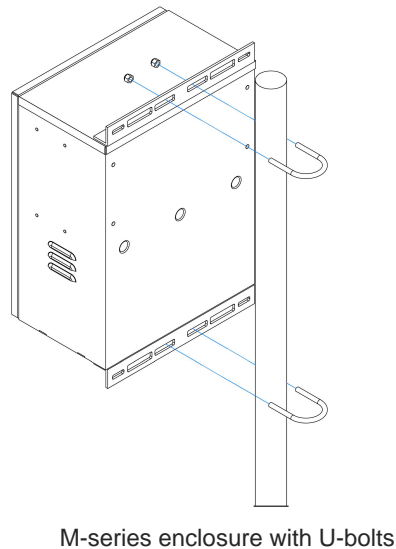
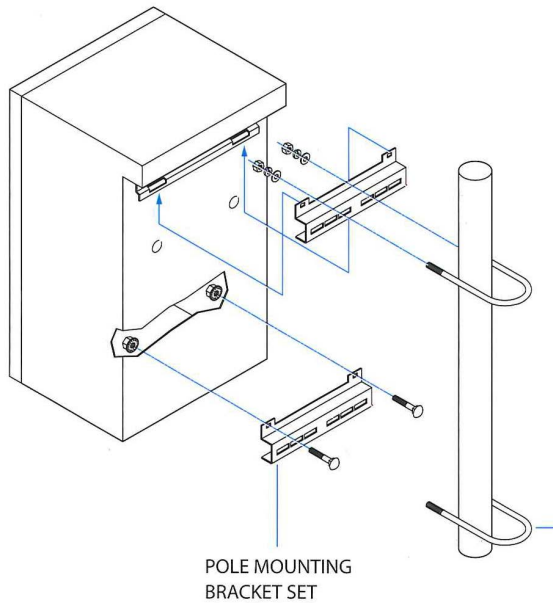

Ground Mounted Enclosure

1. Install the base mounting pads at the desired location using 1/2 inch concrete fastening hardware. Refer to the chart for dimensions and the diagram for enclosure mounting hole locations.
2. Check alignment and tighten bolts.

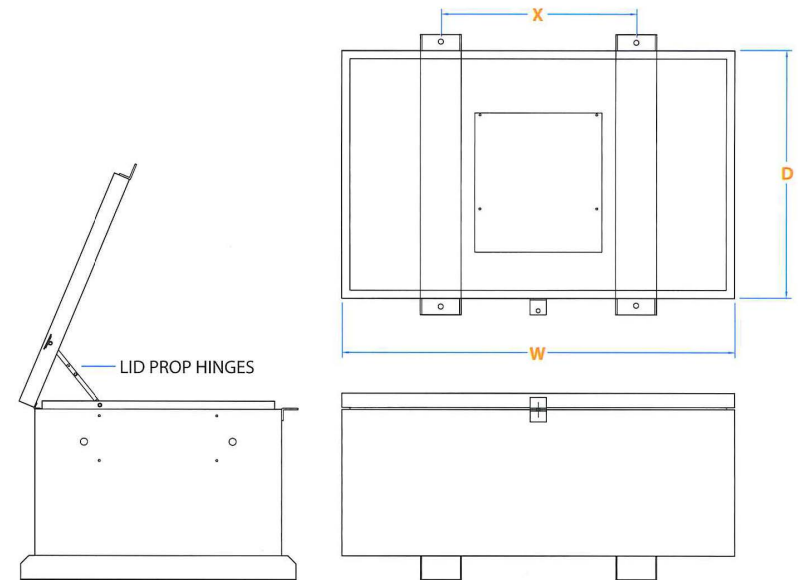

Control Panel Installation

3

Side of Pole Mount Enclosure (Chest Enclosure Same)

1. Remove second set of supplied nuts from mounting studs located on the side wall of the enclosure
2. Adjust first set of nuts on each stud to the same distance from enclosure wall leaving enough stud exposed for control panel and second nuts.
3. Install control panel and second set of nuts as shown below.
4. (Optional) If your system comes with an I/O panel, mount it to the side studs of the enclosure using the same procedure.
5. Verify all breakers are in the OFF (open) position.
6. Ground the control panel to the enclosure (see grounding below).
7. Install Batteries in enclosure (Do not connect wires yet).

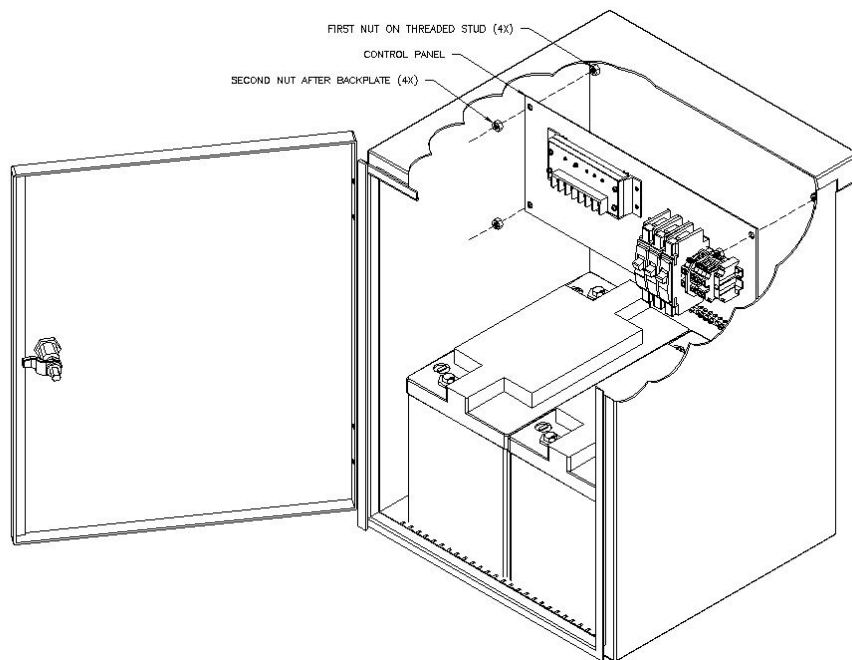

Grounding

Set all circuit breakers in enclosure to OFF (open)

Install ground kit (provided) per figure below. Use wire rated for outdoor use per local codes and size per NEC A.690 for system earth grounding. Verify system neutral bonding is per local code.

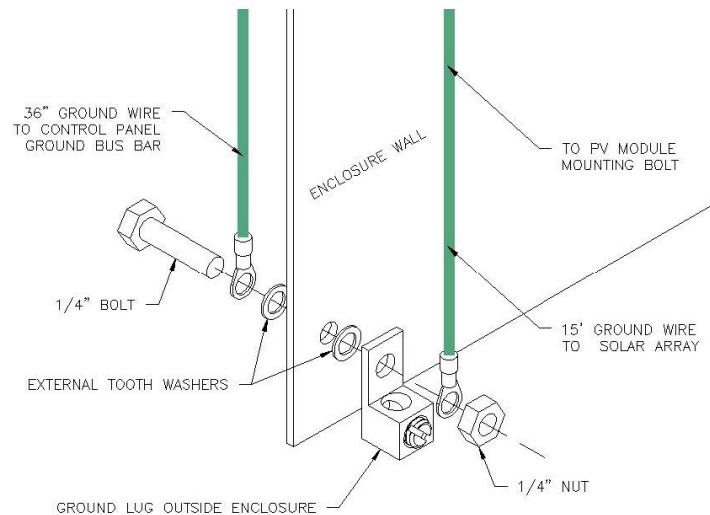

Electrical Installation

4

PV Array Wiring with Tray Cable

Set circuit breakers to OFF (open) and remove fuses in enclosure (if provided).

1. Route the output conductors from the PV panel to the enclosure. Secure the conductors to the PV panel frame or the mounting surface using wire ties or other restraining hardware (not provided). Install the cord grip fitting to the rear of the enclosure using the 1/2 inch knock out provided.
2. Inside the enclosure, mate the PV array PV(+) conductor to the controller PV(+) terminal block. Mate the BLACK PV(-) conductor to the controller PV(-) terminal block. Mate the PV array GREEN GND conductor per instructions in grounding section.
3. For all connections use correct interconnect cables and tray cable (see figure right).

Note: Configurations on the right are with 12V modules. For 24V modules the array voltage will be double the value shown for the configuration.

Tray Cable

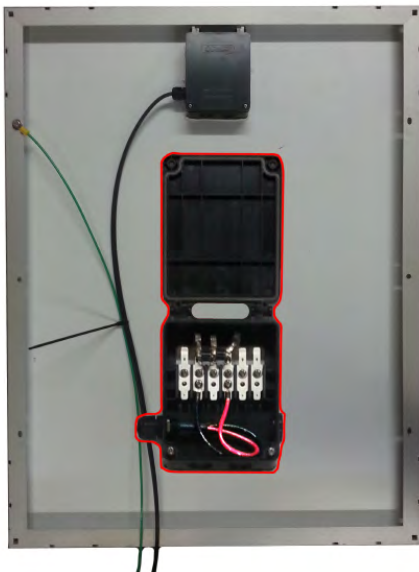

Conduit



PV Panel Wiring (bottom view)

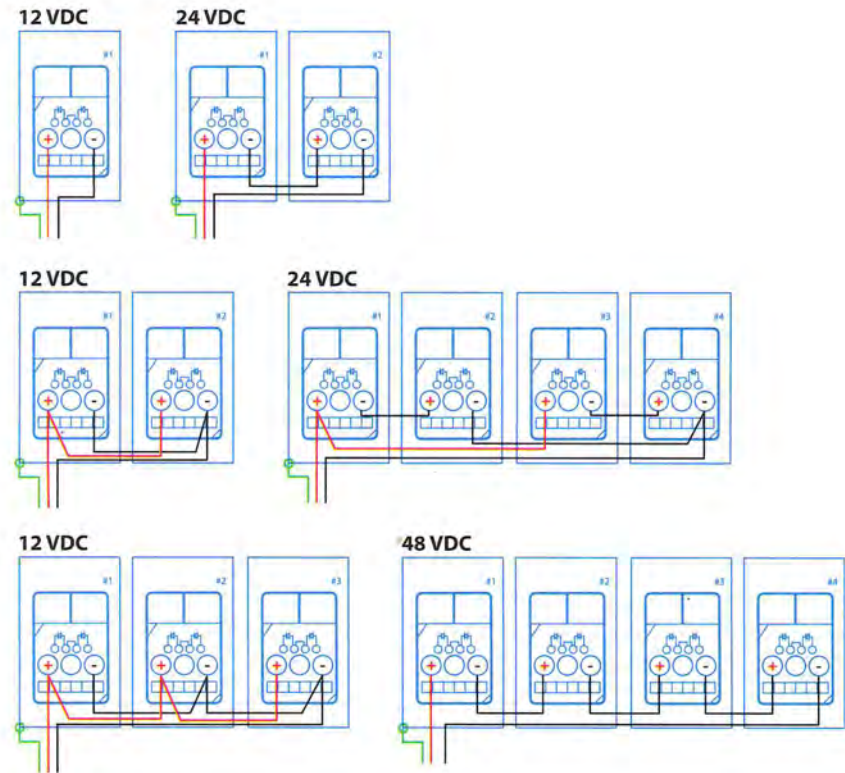

For more than two strings, use a combiner I/O Panel and refer to the diagram included with the panel for wiring instructions.

Battery Installation

5

Battery Wiring

For 12V systems

Each 12V battery is in parallel with the next. Connect the RED jumper from BAT 1 POSITIVE (+) terminal to the BAT 2 POSITIVE (+) terminal and the BLK jumper from BAT 1 NEGATIVE (-) terminal to the BAT 2 NEGATIVE (-) terminal. Repeat this pattern for each battery.

For 24V systems

Each pair of 12V batteries are in series and form one string. Connect the BLK jumper from BAT 1 NEGATIVE (-) terminal to the BAT 2 POSITIVE (+) terminal. Repeat this pattern for each series string.

Each series string must be connected in parallel to complete the bank wiring. Connect the RED jumper from BAT 1 POSITIVE (+) terminal to the BAT 3 POSITIVE (+) terminal, and the BLK jumper from BAT 2 NEGATIVE (-) terminal to the BAT 4 NEGATIVE (-) terminal. Repeat this pattern for each parallel pair.

For 48V systems

Each quadruple set of 12V batteries are in series and form one string. Connect the BLK jumper from BAT 1 NEGATIVE (-) terminal to the BAT 2 POSITIVE (+) terminal, BAT 2 NEGATIVE (-) terminal to the BAT 3 POSITIVE (+) terminal, BAT 3 NEGATIVE (-) terminal to the BAT 4 POSITIVE (+) terminal.

Each series string must be connected in parallel to complete the bank wiring. Connect the RED jumper from BAT 1 POSITIVE (+) terminal to the BAT 5 POSITIVE (+) terminal and the BLK jumper from BAT 4 NEGATIVE (-) terminal to the BAT 8 NEGATIVE (-) terminal. Repeat this pattern for each parallel pair.

Final Connection

Inside the control/battery enclosure, connect the controller RED BAT (+) wire to the battery bank POSITIVE (+) terminal. Connect the controller BLK BAT (-) wire to the battery bank NEGATIVE (-) terminal.

I/O Panels

For I/O Panel wiring, refer to the diagram provided with the panel.

12 VDC

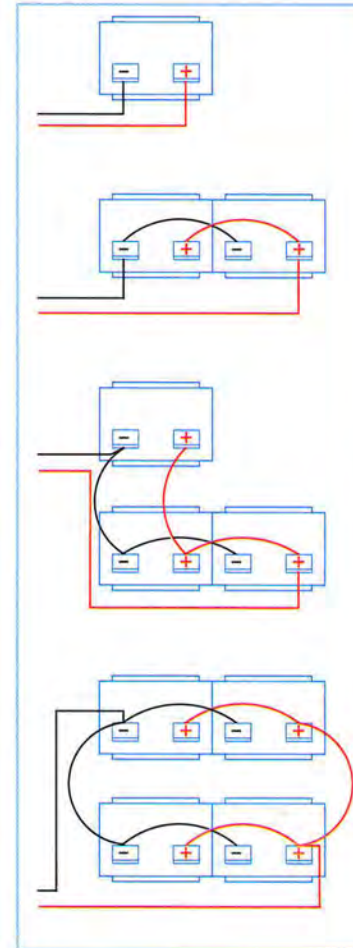

24 VDC

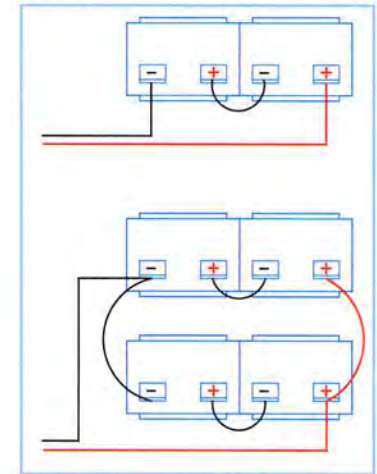

48 VDC

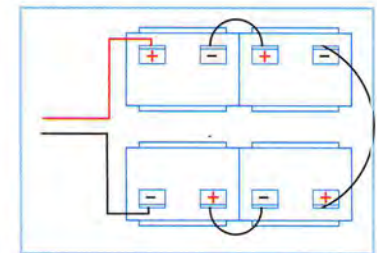

Wiring Legend

— RED - POSITIVE
— BLACK - NEGATIVE

System Testing

6

Confirm all connections, fittings, and fasteners are secure and the PV array surface is clean and facing South.

Measure Voltages (Confirm all breakers are off before measuring)

Verify both the PV and battery polarity is positive. If negative, reverse wiring to the system and check again.

Measure PV array voltage from the PV(+) terminal to the PV(-) terminal in the enclosure.

12V systems	21VDC (open circuit voltage)
24V systems	42VDC (open circuit voltage)
48V systems	84VDC (open circuit voltage)

Measure battery voltage from either the BAT(+) terminal block to the BAT(-) terminal block or the BANK(+) to the BANK(-) to verify that they are approximately:

12V systems	12-13V
24V systems	24-26V
48V systems	48-52V

Set breakers to the ON (closed) position

On the charge control panel

1. Set the BAT(+) CB2 input breaker
2. Set PV(+) CB1 input breaker
3. Set the LOAD (+) CB3 output breaker

Confirm that the controller status LEDs function properly.

On the charge control panel, measure the voltage from the LOAD(+) terminals to the LOAD(-) terminals which should be the same as the battery voltage.

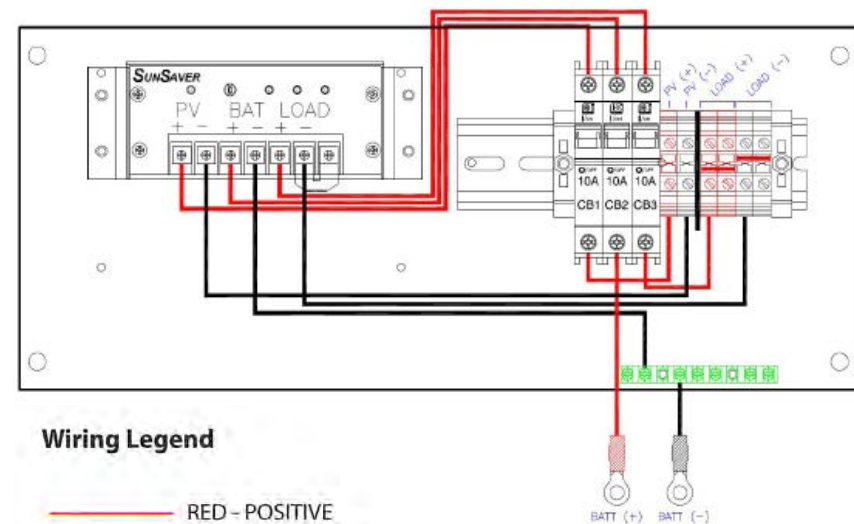

Wiring Legend

- RED - POSITIVE
- BLACK - NEGATIVE
- GREEN - GROUND

Connect Your Equipment

7

1. Turn the Power Ready System OFF.

A. Turn the PV breaker (CB1) OFF

B. Turn the Battery breaker (CB2) OFF

C. Turn the Load breaker (CB3) OFF

D. Connect your equipment to the terminal blocks on the control panel.

2. Turn the Power Ready System ON.

A. Turn the Battery breaker (CB2) ON

B. Turn the PV breaker (CB1) ON

C. Turn Load breaker (CB3) ON

D. Confirm the Power Ready System is providing power to the load.

Calculate Installation Tilt and Azimuth

8

For optimum performance, your PV array should face true south in the Northern Hemisphere (and true north in the Southern Hemisphere). However, when determining direction using a magnetic compass, indicated bearings will vary from true bearings because of the difference between the location of the true and magnetic north poles. This angular difference varies with location on the globe and is called the “declination.”

- Locate your using the web site below. (Great accuracy is not critical).
- Using the magnetic declination from the web site calculate true South. For example, the declination for Washington, D.C., is Approximately -11° ; for Chicago, IL, -3° ; and for Los Angeles, CA, $+14^{\circ}$.
- Determine magnetic south at your site using a magnetic compass.
- If the local declination found in step 2 is negative, true south is that number of degrees added to magnetic south. For example, at Washington, D.C., true south is the same as $180^{\circ} + 11^{\circ} = 191^{\circ}$ indicated. If the local declination found in step 2 is positive, true south is that number of degrees subtracted from magnetic south. For example, at Los Angeles, true south is the same as $180^{\circ} - 14^{\circ} = 166^{\circ}$ indicated.
- Orient your array in the direction of true south (or north if applicable) as determined above.
- The Internet site <http://www.ngdc.noaa.gov/geomag-web/#declination> will calculate magnetic variation from an input of latitude and longitude, or Zip code.

For optimum performance, your PV array should set to a specific tilt angle. To determine the desired tilt angle of the array, use the latitude from step one above.

Take this value and add the factor based on the table below. This will provide the optimum worst case performance with the minimum amount of annual adjustment, based on the winter months (Northern hemisphere).

Latitude range between $90 - 45^{\circ}$ SET TO 60°

Latitude range between $40 - 25^{\circ}$ $+15^{\circ}$

Latitude range between $25 - 15^{\circ}$ $+5^{\circ}$

Latitude range between $10 - 0^{\circ}$ SET TO 15°